

FORMICA  
HOME SOLUTION





# Content

01

Our Story behind this collection

04

FORMICA Kitchen

08

FORMICA Wardrobe

12

FORMICA Furniture

18

TUET

20

FENIX

22

FORMICA

24

Design & Handle Options

26

Wall Cladding

34

About Our Group

35

Sustainability

36

About Formica

## INTRODUCTION

# Our Story behind this Collection

### Elegantly sensual to the eye and the touch

Welcome to our latest collection, where we take beauty beyond the surface. Now offering a complete solution for home and office décor, our exquisitely crafted furniture and products feature texturised surfaces and premium materials, delivering both style and substance for exceptional interiors.





## Professional Craftsmanship

Our expert craftsmanship begins with precision bonding, using advanced press technology to eliminate manual gluing and ensure seamless adhesion. By crafting from full panels before cutting and assembly, we guarantee smooth, flat surfaces. Our high standards extend to using hot melt edge banding for solid colours, paired with meticulous post-processing and rigorous quality checks to achieve flawless, smooth edges - quality and reliability, built to last.



## How We Add Value



**Professional Craftsmanship**  
Quality and reliability, built to last.



**Safe Materials**  
Giving you the peace of mind that your space is as safe as it is beautiful.



**Distinctive Design**  
A curated selection of standout designs that are simply part of the furniture.



## Safe Materials

At the heart of our craftsmanship is a deep commitment to your safety and well-being. We carefully select materials that are as safe as they are durable, avoiding toxic substances and volatile organic compounds that release harmful vapors. Instead, we use PVA/PVAc wood glue, commonly trusted in children's crafts, ensuring both strength and safety.

Our products are GREENGUARD and GREENGUARD Gold certified, meeting the highest indoor air quality standards. But we don't stop there. We conduct regular testing at globally recognised labs to ensure every piece meets rigorous global standards, giving you the peace of mind that your space is as safe as it is beautiful.

## Distinctive Design

We proudly offer a curated selection of standout designs, featuring FENIX innovative materials, TUET modern deep textures, and Formica Laminates, timeless surfaces that blend classic and contemporary styles. Unlike others, we use double-sided doors, rather than non-descript backings, because true quality matters, inside and out. Our exclusive design combinations aren't found elsewhere, ensuring a unique, hard-to-replicate aesthetic.

With every carefully selected material and component, we deliver interiors that make a lasting impression, where distinctive design is simply part of the furniture.



59690G

0964PT

FENIX  
0725  
12mm matched core

FENIX  
0725

08710G

# FORMICA Kitchen

Discover our extensive selection of Formica and FENIX colors. Whether you seek a sleek modern aesthetic or a classic traditional look, we have the perfect match for your vision. Our diverse palette caters to all tastes, ensuring quality is never compromised. Elevate your kitchen with durable materials that enhance both style and functionality. Choose from a variety of finishes to create the ideal space for your home

# FORMICA Kitchen

Affordability does not compromise quality. Our luxurious yet accessible pieces help you create a beautiful home without exceeding your budget. When selecting kitchen cabinets or other furniture, consider the variety, quality, pricing, and customer service available.



## Benefits



**Varied Options**  
Tailors designs to match your unique style preferences.



**Affordable Quality**  
Delivers premium materials and craftsmanship at prices that fit any budget.



**Luxurious Accessibility**  
Elegance and durable with everyday practicality for seamless home integration.



# FORMICA Wardrobe

Discover our extensive selection of Formica and FENIX colors. Whether you seek a sleek modern aesthetic or a classic traditional look, we have the perfect match for your vision. Our diverse palette caters to all tastes, ensuring quality is never compromised. Elevate your kitchen with durable materials that enhance both style and functionality. Choose from a variety of finishes to create the ideal space for your home

9436LB

7976LM

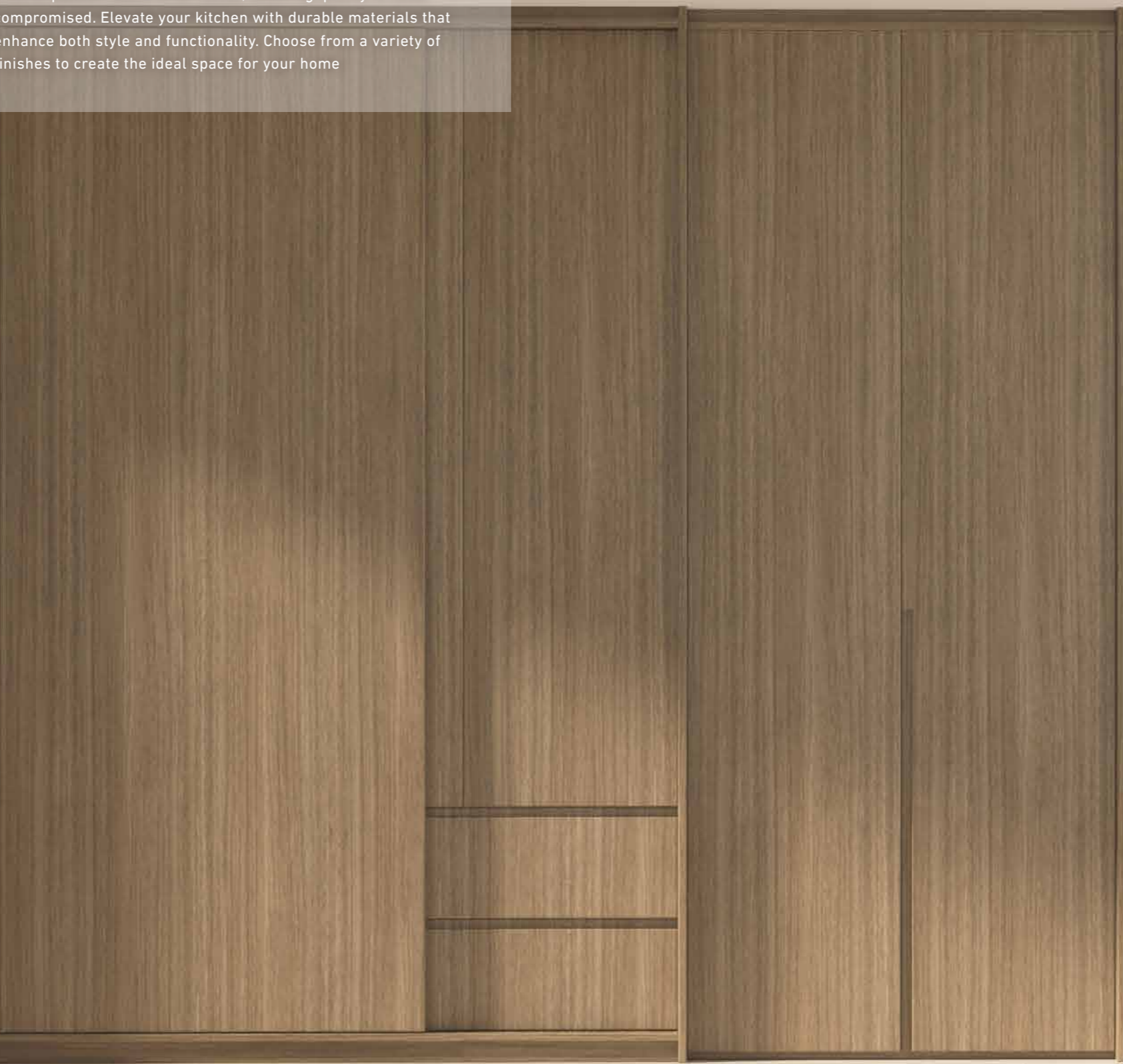



88600G

7976LM

# FORMICA Wardrobe

As you furnish your home, remember that each choice enhances comfort and aesthetic appeal. Let Formica x FENIX help you create an environment where elegance meets functionality.



FENIX  
0751

CR9532LM



1256WR

59660G

# FORMICA Furniture



CR5795NT

TUET  
4645

# FORMICA Furniture





# FORMICA Furniture

Imagine walking into a space that not only looks luxurious but also feels inviting. With our innovative solutions for modern living, you can customize furniture to reflect your personal style and meet your functional needs. Whether you're looking to furnish your living room, dining area, or bedroom, our collection offers a range of configurations that cater to every taste.



## Benefits



**Functional Design**  
Balances aesthetics with practical everyday usability.



**Varied Configurations**  
Offers diverse options to suit individual tastes.



**Cross-Material Option**  
Use any material in the range (incl. TUET, FENIX, Formica)



# TUET



Veneer Edgeband

## Deep Surfaces

TUET reveals the harmony of fluid contrasts, **visually and tactilely**. By immersing into the waves of the deep surface, the light transforms each furnishing scene into an evocative composition characterised by light and shadow, which varies according to the time of day.

-  Contrast
-  Smooth Touch
-  Tactility
-  Wavy Path



Metal Frame

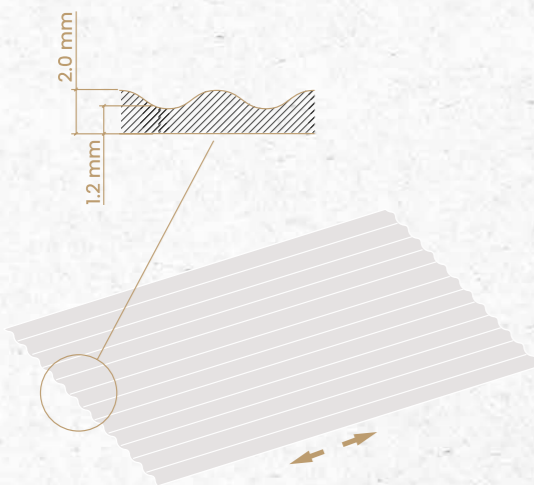

CR5795NT

TUET  
4645

# FENIX®

Italian design since 2013

Created with proprietary technologies, the external surface of FENIX is characterised by the use of next-generation acrylic resins, hardened and fixed through an Electron Beam Curing process. Experience the difference.

FENIX is a powerful system including innovative materials and interior solutions to create design elements suitable for a wide range of applications and market sectors.

 Low light reflectivity  
extremely matt surface

 Soft touch

 Anti-fingerprint

 Thermal healing  
of superficial  
micro-scratches

Straight  
Edge

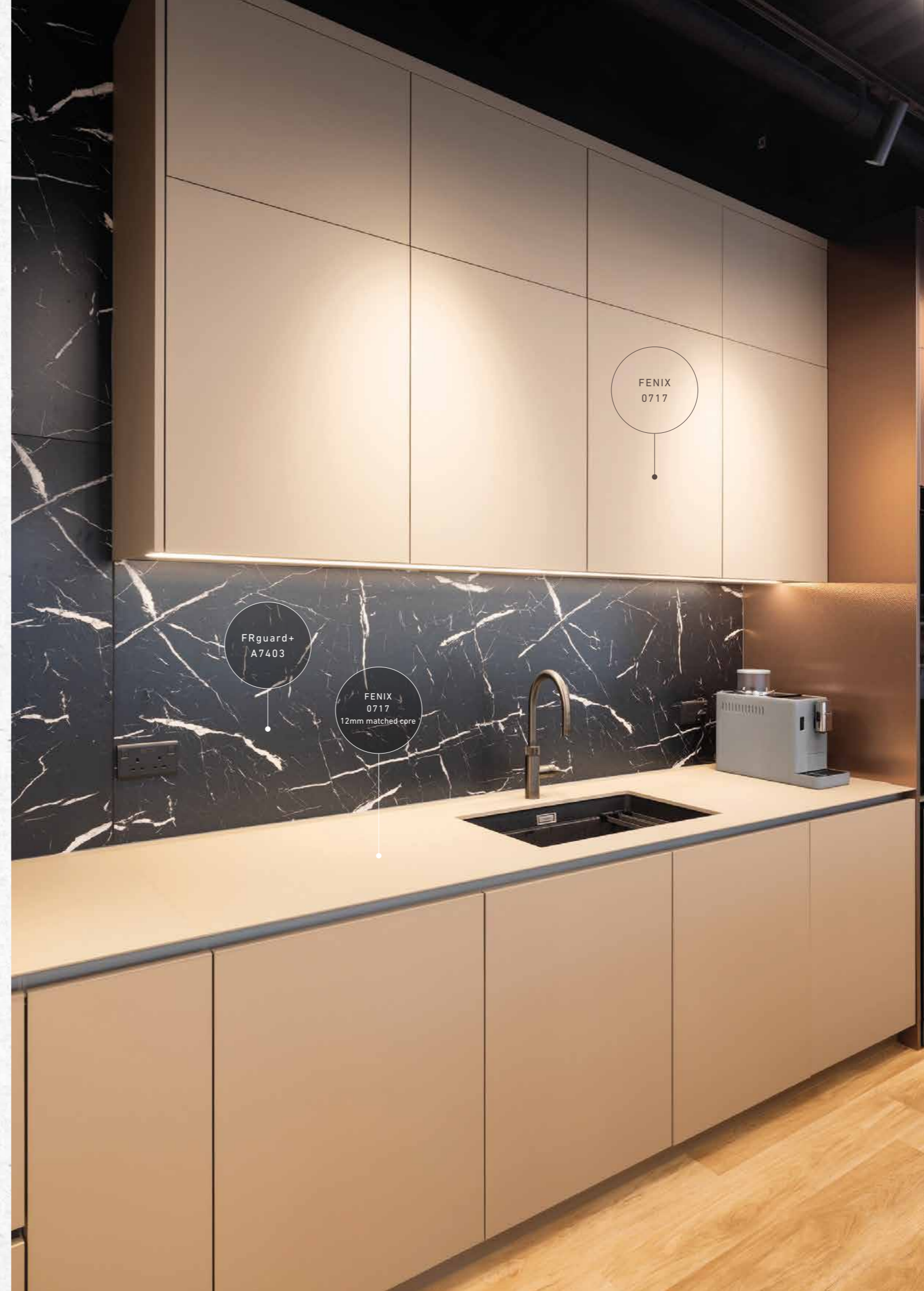

# FORMICA

## Durable Antimicrobial Surfaces

A **next-generation antimicrobial surfacing material** that is capable of reducing microbe count on a surface by up to 99%, with high-wear and scratch-resistant properties.

With superb quality and innovative materials, you no longer have to compromise aesthetics over durability.

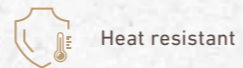
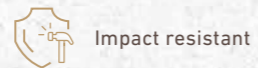
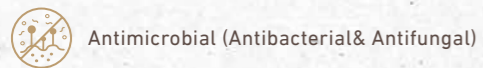

# Design Options

 **Customize Design**  
 ① Subject to Formica Designer's approval

 **Customize Size**  
 ✓ Yes

 **Customize Color**  
 ✓ Yes



 **Customize to other Formica material**  
 ① Subject to Formica Designer's approval

 **Customize Substrate**  
 ✗ No (plywood only)

 **Customize Hardware**  
 ① Subject to Formica Designer's approval





For more product information, please visit [www.formica.com](http://www.formica.com)  
 For more technical information and certification, please visit [www.formica-asia.info](http://www.formica-asia.info)

# Handle Options

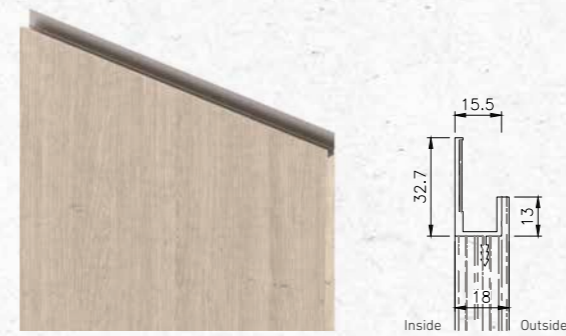

## J Handle

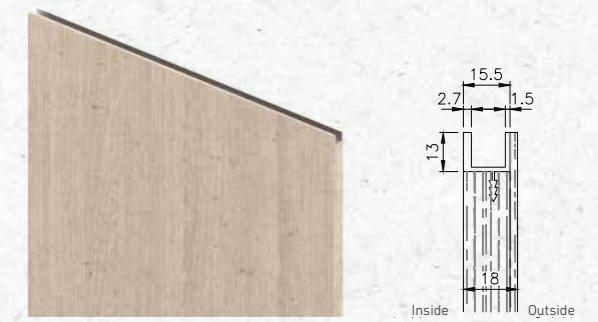

 Aluminium  Rose Gold

## U Handle



 Aluminium  Rose Gold

## B Handle

Built-in straight handle

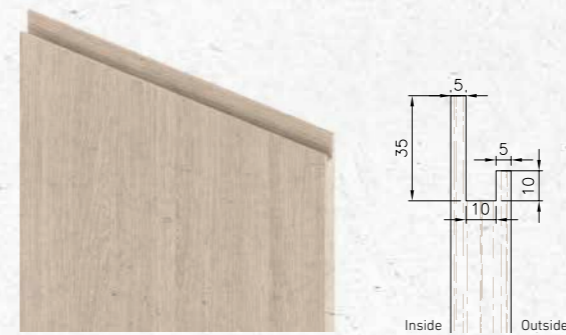

## Chamfered Edge

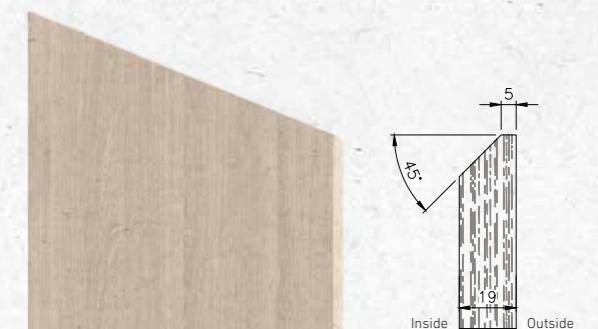

## BV Handle

Built-in V-shaped handle

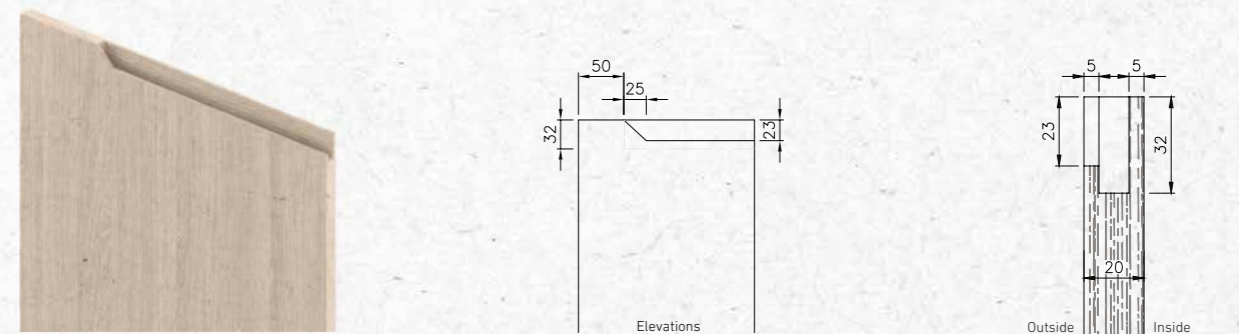

Handle options are not applicable for TUET panels.

# Wall Cladding

9306NM

093706





6406NT



7976LM

5479LM

# Features

**Rough Wall Compatibility**  
Target for rough wall installation, brick/cement/ painted/ wallpaper base, rugged wall

**Fast and Easy Installation**  
Quicker and simpler to install than traditional wood framing

**Adhesive-Free Installation**  
No structural adhesive needed during fabrication. Cost- and time-saving

**Easy to maintain**  
Replaceable panels make maintenance quick and simple

**Slimmer Profile**  
Offers a thinner overall profile compared to traditional wood framing

# Connection

## Middle Groove



Linear connecting - middle groove

## Corner



Outer corner



Inner corner

# Trim

Standard Color  Aluminium  Dark Grey



Inner Corner Profile



Outer Corner Profile



Trim



End Profile



End Profile w/LED



Trim w/LED

# Cutout

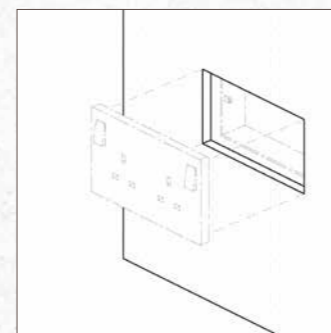

Dual socket plate

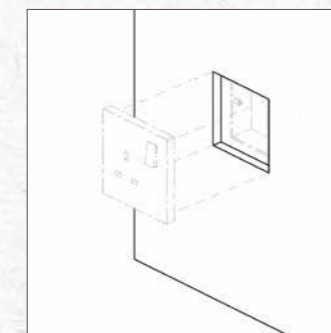

Single socket plate

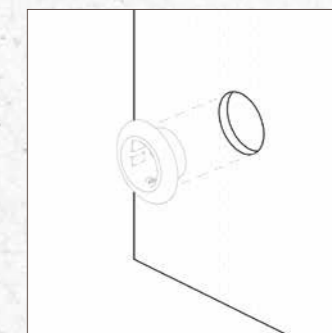

Round cutout

# Structure

Formica Wall Cladding features a significantly slimmer profile than traditional 50mm wood framing, delivering a sleek, modern aesthetic without compromising strength or stability. Its reduced thickness maximizes interior space, making it ideal for compact areas or projects focused on space efficiency - all with a clean, professional finish.



# Hanger



Façade

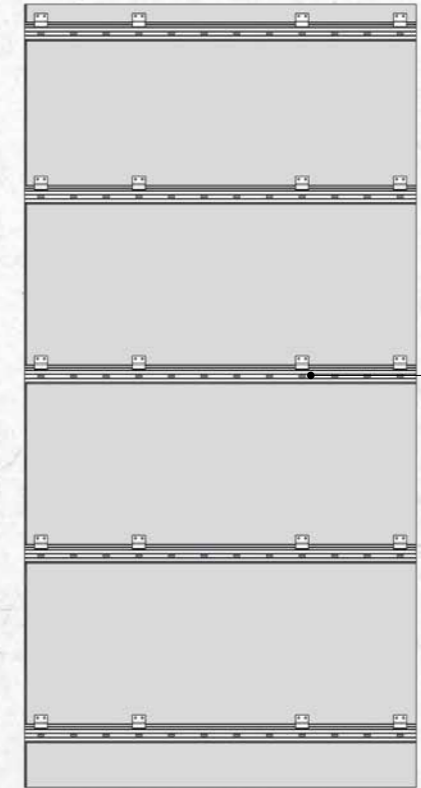

Back

Hanger

Formica Wall Cladding adapts seamlessly to various surfaces—including brick, cement, painted walls, and wallpapered bases. Its adhesive-free installation reduces material costs, streamlines the process, minimizes disruption, and enhances durability—making it a cost-effective and eco-friendly choice for both new builds and renovations.

**Overall Thickness**  
Nominal 35mm room space, depends on wall flatness

**Surface / Backer**  
Formica Laminate

**Substrate**  
Plywood

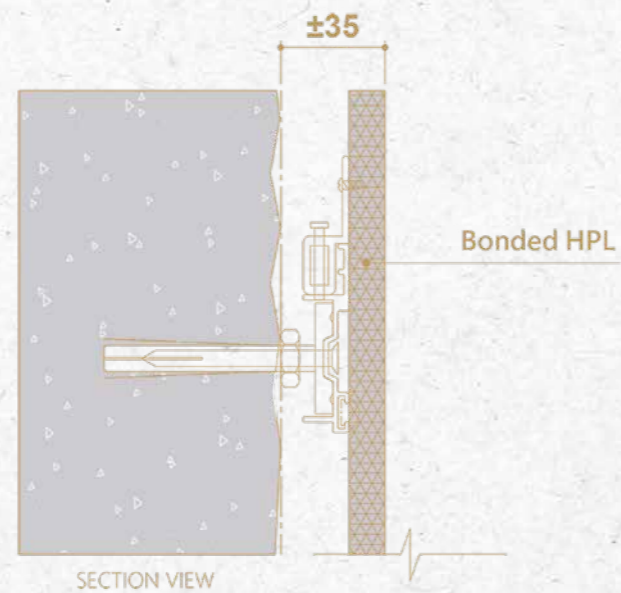

Top hanger with leveling function



General hanger

# ABOUT THE GROUP

We are part of the leading global group in surface materials. We are FENIX, Formica, Homapal, Arpa, Westag, Trespa, Hartson-Kennedy and Direct Online Services. All active in material technology. Panels, doors, worktops: our products range from HPL to solid surface, and from decorative metals to FENIX. Our 6,000 employees work in 40 countries around the world and our products are marketed in many more.

We are not just about creating physical spaces to live, work and play in. We are about setting the stage for a warm and aspirational future. For that reason, we take extraordinary care with the spaces you create. And ensure every detail is crafted to be felt, by touch and by the heart.



# SUSTAINABILITY

Formica Group is a leading provider of stylistic, smart and sustainable surfacing solutions for commercial and residential customers worldwide. Since 1913, the heritage of Formica Group has been founded on quality, service, and innovative product lines.

As the world's largest manufacturer of High Pressure Laminate (HPL), our sustainability policy is built upon being "god" and having a positive impact on the world around us.

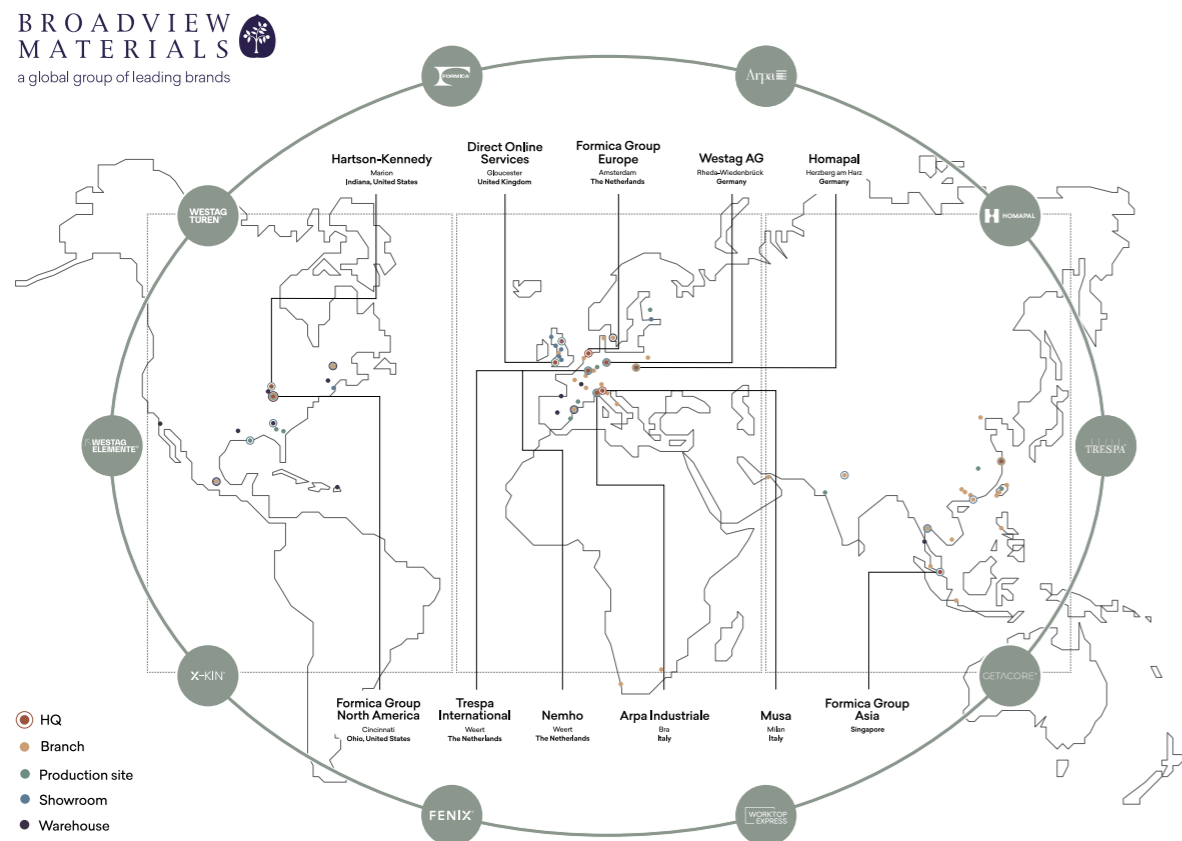

# SINCE 1913, FORMICA® DESIGNS FOR TODAY WITH FOREVER IN MIND.

## FORMICA'S FOUNDING

Formica® was founded in Cincinnati in 1913 by two young men, Herbert A. Faber and Daniel J. O'Conor. Their high-pressure plastic resins were intended to serve as electrical insulators replacing mineral Mica, which was used for that purpose at the time. Hence the name "Formica" was chosen. World-renowned artists and architects had also begun to recognize the potential of the decorative laminates and specified them for modernist and art deco interiors.

## FORMICA'S SERVICES

Formica® offers a complete range of surface decorative products with Protec+® technology (High Pressure Laminate, Formica® Compact®, Formica® Custom Graphics™ and FRguard®+), premium decorative products (DecoMetal® by Homapal and FENIX®) and a range of functional products (CHguard™). All Formica® High Pressure Laminates conform to European BS EN438 standards. And meanwhile, we have got the certification of ISO 9001: 2015, ISO 14001: 2015, ISO 45001: 2018, and GREENGUARD.

Formica® owns manufacturing bases worldwide, with five located in Asia. Major bases are located in Shanghai (China), Jiujiang (China), Hsinchu (Taiwan), Bangkok (Thailand) and Ahmedabad (India).

## FORMICA'S LOGO HISTORY



## Formica® Asia Offices

### Taiwan

#### Formica Taiwan Corporation

Taiwan – Taipei  
6F., No. 68-70, Section 3, Nanking East Road,  
Zhongshan District, Taipei City 104, Taiwan  
Tel: (886-2) 2515-1017  
Fax: (886-2) 2517-0542

Taiwan – Taichung  
No. 122, Jingke Rd.,  
Nantun Dist., Taichung City 408, Taiwan  
Tel: (886-4) 2359-5680  
Fax: (886-4) 2359-5890

Taiwan – Kaohsiung  
15F.-2, No. 110, Sanduo 4th Road,  
Lingya District, Kaohsiung City 802, Taiwan  
Tel: (886-7) 330-2365  
Fax: (886-7) 330-2175

### China

#### Formica (China) Trading Co., Ltd

China – Shanghai  
Room 407, Office Building Block B,  
National Convention and Exhibition Center,  
181 Laigang Road Xujing Town, Qingpu District,  
Shanghai 201702, China  
Tel: (86-21) 6010-2688  
Fax: (86-21) 6010-2659

China – Beijing  
Room 2508, Tower A, Lecheng Center  
No. 20 East Third Ring Middle Road Chaoyang District,  
Beijing 100020, China

China – Guangzhou  
Rm. 1209, Jie Tai Plaza,  
No. 218-222 Zhongshan 6 Road,  
Yuexiu District, Guangzhou 510180, China  
Tel: (86-20) 8132-0258/0259  
Fax: (86-20) 8132-0033/0039

China – Dongguan  
Rm.1412, Block 3, One Mall, No.200 Hongfu Road,  
Nancheng District, Dongguan 523073, China  
Tel: (86-769) 2270-2216/2219  
Fax: (86-769) 2278-1770

China – Shenzhen  
506, 5th Floor, Block A TCL Building,  
Gaoxinnan 1st Road,  
Nanshan District, Shenzhen 518053, China  
Tel: (86-755) 8287-4868  
Fax: (86-755) 8287-4880

### Hong Kong

#### Formica (Asia) Limited

Hong Kong Showroom  
G/F., Pico Tower, 66 Gloucester Road  
Wanchai, Hong Kong  
Tel: (852) 2155-5183  
Fax: (852) 2153-2283

Hong Kong Office  
Room 1305-9, 13/F., Olympia Plaza,  
255 King's Road, North Point, Hong Kong  
Tel: (852) 2598-0117  
Fax: (852) 2598-6577

### Thailand

#### Formica (Thailand) Co. Ltd.

51/27 Moo 2 Poochaosamingprai Road,  
Bangyaprak, Phrapradaeng,  
Samutprakarn, 10130 Thailand  
Tel: (66-2) 701-9600  
Fax: (66-2) 384-7537

Thailand Sales Office  
128 A-Square, Soi Sukhumvit 26,  
Khlongton, Khlongtoey, Bangkok 10110  
Tel: (66-2) 285-4473 / (66-2) 285-4474  
Fax: (66-2) 285-2899

### Singapore

#### Formica (Singapore) Pte. Ltd.

38 Armenian Street Singapore 179942  
Tel: (65) 6514-1313  
Fax: (65) 6846-7030

### Malaysia

#### Formica (Malaysia) Sdn. Bhd.

B-10-3A, Level 10, Menara Bata, PJ Trade Centre,  
No. 8, Jalan PJU 8/8A, Bandar Damansara Perdana  
47820 Petaling Jaya, Selangor D.E, Malaysia  
Tel: (60-3) 7710-0512  
Fax: (60-3) 7727-0510

### India

#### Formica Laminate (India) Private Limited

Block No.591/592, 6th K.M.Stone, Kalol-Vamaj Road  
Village-Piyaj, Tal:Kalol Gandhinagar – 382721  
Gujarat, India  
Tel: (91-27) 6467-4000

### Indonesia

#### Sales Representative Office

Sovereign Plaza 1st Floor Unit B  
Jl. TB Simatupang Kav.36  
Jakarta Selatan, Indonesia 12430  
Tel: (62-21) 2960-1551

### Philippines

#### Sales Representative Office

Unit 1401, 14th Floor, MDI Corporate Center  
10th Avenue Corner 39th Street, Bonifacio Global City,  
Taguig City, Philippines  
Tel: (632) 8553-9996  
Fax: (632) 8856-0407  
Em: phsales@formica.com

### Vietnam

#### Sales Representative Office

Level 4, 414 Nguyen Thi Minh Khai Street,  
District 3, Ho Chi Minh City, Vietnam  
Tel: (84-28) 3832 6128  
Fax: (84-28) 3832 6129

### Dubai

#### Formica B.V.

Clover Bay Tower, Office 1112  
Marasi Drive, Business Bay, Dubai, U.A.E.  
Tel: (971) 04 329 8280

### Korea

#### Formica Korea Corporation

Suite 575, 5F, 4 Gukhoe-daero 72-gil,  
Yeongdeungpo-gu (IBPIA Building, Yeouido-dong),  
Seoul, Republic of Korea

HK-160400-112025



© 2025 FORMICA® ALL RIGHTS RESERVED.